

Research article

# OPTIMAL DESIGN AND CONTROL OF SOLAR/ELECTRIC/REDUCED FUEL CONSUMPTION(IC ENGINE) HYBRID POWERED VEHICLE (SEFPHV) TECHNOLOGY

Balamurugan. T\*, Manoharan.S<sup>#</sup>

\*Research Scholar, Department of Electrical and Electronics Engineering, Karpagam University, Coimbatore, India

<sup>#</sup> Professor, Department of Electronics and Instrumentation Engineering, Karpagam College of Engineering,  
Coimbatore, India

9843943308

E-mail: [balaeete.mtech@gmail.com](mailto:balaeete.mtech@gmail.com), [maniosh07@yahoo.co.in](mailto:maniosh07@yahoo.co.in)

---

## ABSTRACT

This paper proposes an implementation of Solar/Electric/Reduced Fuel consumption(IC Engine) Hybrid Powered Vehicle (SEFPHV) technology which is the combination of multi sources. The Vehicle will run with help of solar power, electric power and less amount of fuel energy used to charge the batteries and to drive. Rechargeable batteries are used to drive the BLDC motor into vehicle. Batteries are charged with the help of solar power, plug-in and altered IC Engine with generator. In sunny days, solar panel is used to charge the batteries. In spite of using IC engines very less amount of fuel energy is used to charge the battery in rainy seasons. This multi charging vehicle can charge itself from both solar power, altered IC Engine with generator and plug in. For controlling speed of the motor, a switch was designed with two tapping, giving different values of resistance at each tapping. The performance of the SEFPHV was found to be satisfactory for the load of two people with the average speed of 45-50 KM/hr to a mileage of 60 KM with reduced charges. Simulation and Experimental results shows that the performance of SEFPHV to confirm the theoretical analysis and their control schemes has been analyzed and validated. **Copyright © IJRETR, all rights reserved.**

**Keywords:** Solar module, PMDC generator, BLDC hub motor, Rheostat Control, Step-down Transformer, IC Engine, Diode rectifier and Battery Bank.

## I. INTRODUCTION

Now a day's Non Renewable energy sources are being destroyed. Due to this more consumption of fossil fuels for automobiles. Increasing awareness of air quality and interest in innovative vehicles stimulate the research activity to improve the propulsion systems by reducing the vehicle emissions[1]. Vehicles which predominantly use Electric batteries for energy storage, Electric motors and controllers for their operation are known as Electric vehicles[2]. Electric vehicles are speedily gaining importance once again in today's world. Owing to mainly three reasons; they do not produce exhausts and toxic gases, they are noiseless vehicles; and limitations of non renewable resources, and they are promising vehicles for future [4]. The brief study of hybrid solar vehicle of efficient in our daily life because now day's pollution and fuel rate is very big problem many people having fuel vehicles. Use of solar vehicle is being used for vehicle, less consumption of fuel, hybrid solar vehicle are effective reducing global warming and environment problem in big frame. Various advantages for hybrid vehicle by using solar technology [5].

1. Reduction in fuel demand.
2. Give clean energy which will reduce the carbon dioxide emission.
3. Minimizing the pollution problem.

Electric vehicles use batteries and motors as their normal operating components. They are many times supplemented with other energy sources such as IC Engine, Solar cells, Plug in etc, depending upon their type. The Electric vehicles can be classified into following kinds, based on their sources of power and their utilizations;

1. Battery Electric vehicles.
2. IC Engine- Electric Hybrid Vehicles.
3. Fuelled Electric Vehicles.
4. Electric Vehicles using supply lines.
5. Solar powered vehicles.

In this paper, Solar/Electric/Reduced Fuel consumption(IC Engine) Hybrid Powered Vehicle (SEFPHV) technology will be introduced. This hybrid vehicle will run with the help of solar power, plug in and less amount of fuel energy used to charge the batteries. SEFPHV system which is combination of three sources. The Sources are

- (i) Solar power
- (ii) Plug in Electric power supply
- (iii) Reduced Fuel consumption - IC Engine.

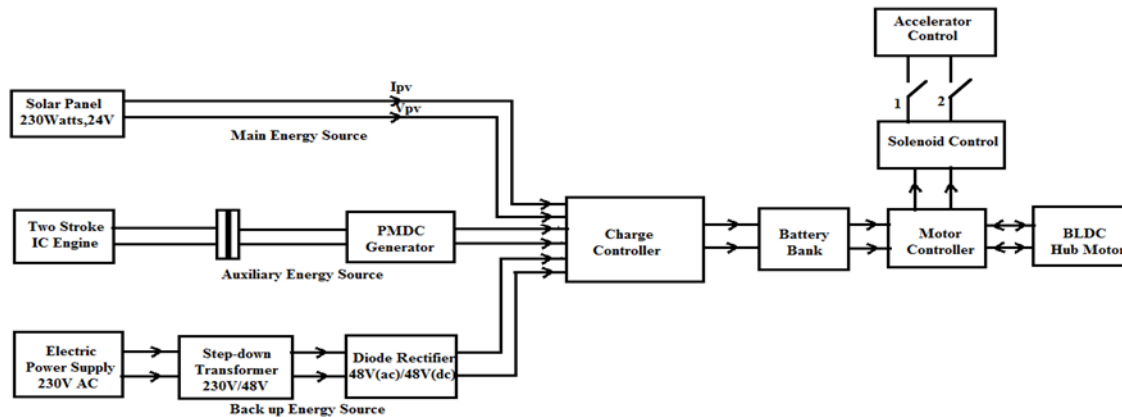
Solar/Electric/Reduced Fuel consumption(IC Engine) Hybrid powered Vehicle (SEFPHV) have the potential of sustainably reducing petroleum consumption and vehicular CO<sub>2</sub> emissions relative to conventional vehicles. The mechanical energy produced by the IC Engine is transferred to PMDC generator and convert Electrical energy. The produced Electrical energy is applied to charge controller and output of the charge controller is given for charging the battery. Two Solar panels each with a rating of 230 Watts are connected to the top of the vehicle to grab the solar energy and then controlled it with a help of charge controller. During sunless conditions, household Electric supply of 230V is reduced with a step-down transformer to 48V and then it is converted into DC with a rectifying unit to charge the batteries. Using the above additional methods are implemented and to reduce the fuel consumption in automobiles. The power from the additional sources is fed to the charge controller.

The paper is organized as follows. The system configuration and overview are discussed in section II. The Specifications of proposed system are discussed in section III. Section IV discusses the overall design charge controller & altered IC engine specifications of proposed system. Section V gives the design procedure of simulation

setup of proposed system. Section VI gives the overall hardware implementation of proposed SEFPHV. Section VII concludes the paper.

## II. SYSTEM CONFIGURATION AND OVERVIEW

The proposed integrated system consisting of solar module, charge controller, PMDC generator, BLDC Hub motor, IC Engine, Rectifier unit and batteries are required for the vehicle.



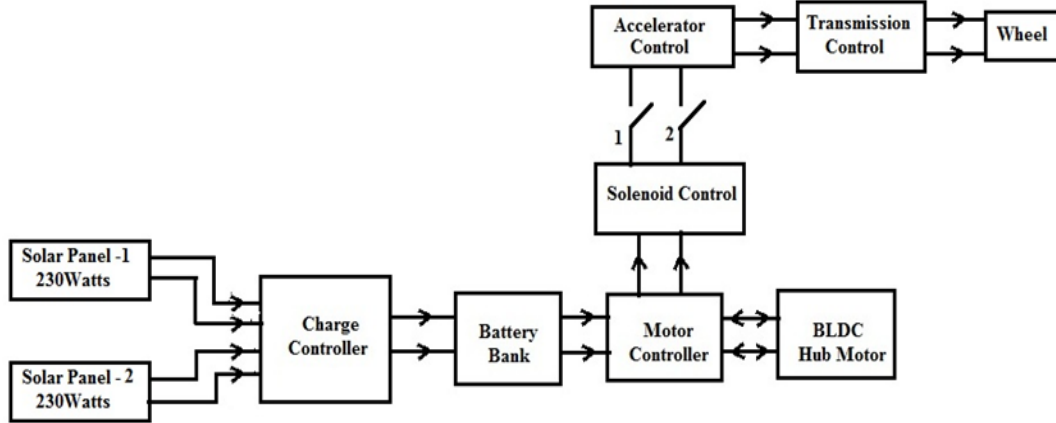
**Figure1:** Overall Design of System Configuration

In Fig.1. Shows the schematic diagram of the multisource Solar/Electric/Reduced Fuel consumption(IC Engine) Hybrid powered Vehicle (SEFPHV). The SEFPHV tends to use the solar panel as the main energy source, two stroke IC engine as the auxiliary energy source and the plug in as the backup energy source. In Electrical energy stored in battery are used to drive the BLDC motor. Where BLDC motor is the rear wheel of this vehicle and the control of the motor (BLDC) is processed through the motor controller which gives the electronic commutation to the windings of the motor. Speed of the motor is driven using the electronic accelerator. It is sense the current in the motor and applying triggering pulse to the gate terminal of the controller circuit. The battery when get discharged, IC Engine coupled with the PMDC generator. It will be used to start the charging the battery. To control the output of the generator, charge controller is used to control the input of the battery. In this method, very less amount of fuel will be consumed to drive the vehicle. Charge controller regulates the current from the main energy source, auxiliary energy source and backup energy sources and fed to the power into batteries. Charge controllers are able to reduce the noise and produced during power generation. The hybrid vehicle different modes of operation are represented as shown in Table-I

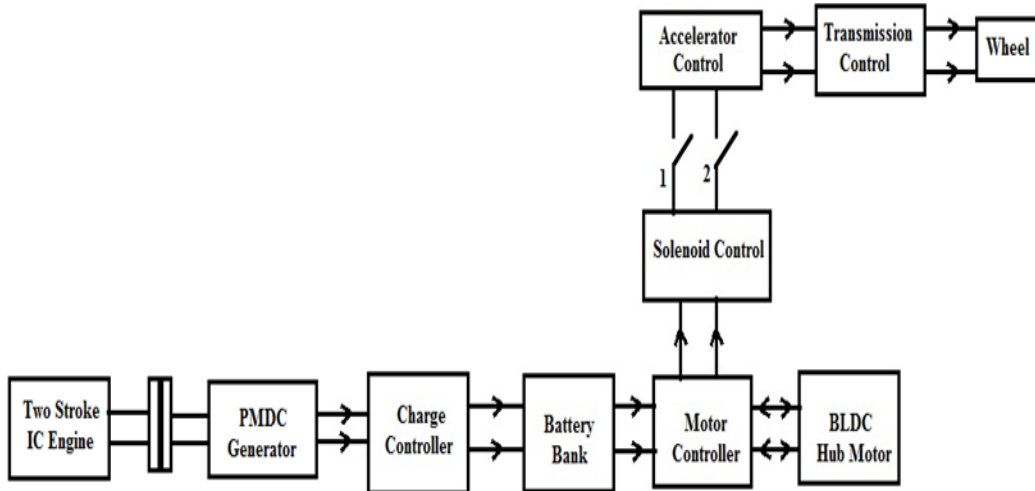
**Table-I:** Modes of Operation

Mode	Energy Source	Type of Energy Source	Storage Device
Mode -1	Solar energy-230Watts(two panels)	Main Energy Source	Battery bank
Mode -2	Two stroke IC Engine	Auxiliary Energy Source	Battery bank
Mode -3	Plug in energy source (with step down transformer & diode rectifier)	Back up Energy Source	Battery bank

In mode 1, solar energy source acts as the main energy source. The battery is charged from the main energy source and the controller circuit controls the power supply to the motor and directly controls the translation speed of the vehicle. Fig.2. shows the mode 1 operation of the vehicle with energy storage.

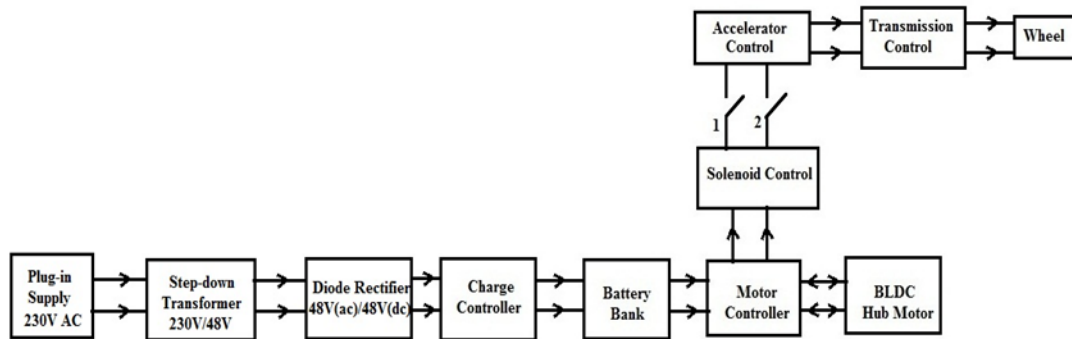


**Figure 2:** Mode 1-operation of vehicle with main energy source.



**Figure 3:** Mode 2-Operation of vehicle with auxiliary energy storage.

In the mode 3, plug-in power supply acts as the back up energy source. The battery is charged from the backup energy source and the controller circuit controls the power supply of the motor and directly controls the translation speed of the vehicle. Fig.4. shows the mode 3 operation of vehicle with energy storage



**Figure 4:** Mode 3-Operation of vehicle with Back-up energy storage.

### III. SPECIFICATIONS OF PROPOSED SYSTEM

#### i. BLDC HUB MOTOR SPECIFICATIONS

Some of the problems of the brushed DC motor are eliminated in the BLDC design. In this motor, the mechanical "rotating switch" or commutator is replaced by an external electronic switch synchronized to the rotor's position. BLDC motors are typically 85–90% efficient or more. Efficiency for a BLDC motor of up to 96.5% have been reported, whereas DC motors with brush gear are typically 75–80% efficient [13]. A Brushless DC Motor (also known as a BLDC Motor), is a synchronous Electric motor powered by a direct current. The Brushless DC Motor consists of a rotating rotor, Neodymium Iron Boron magnets, and a stator. Brushless DC Motors are considered to be an "inside-out" version of a Brush DC Motor; the commutator and brushes are nonexistent, and the windings are located externally, connected to the controller. There are typically two different construction types for the Brushless DC Motor: in runner and out runner configurations. The in runner configuration consists of three stator windings located around the rotor, with permanent magnets as a part of the rotor. The out runner has a reversed relationship between the magnets and the coils. The permanent magnets rotate inside a suspended rotor surrounding the core of the BLDC motor. A Brushless DC Motor is operated by means of an electronic six-step commutation system. Selecting the appropriate Brushless DC Motor requires knowing the requirements of the application, such as torque, speed, size, power and length. New structure of BLDC motor applied for a wheel-hub motor for an electric vehicle. Today the physical structure of BLDC motors is dominated by a massive stator with salient poles as a framework for the windings. This construction results in high weight and in significant energy losses caused by eddy currents and hysteresis losses in the stator material [7]. The Brushless DC (BLDC) motor is used as the drive motor for the vehicle. It's a permanent magnet square wave motor. BLDC motor uses feedback directly of the rotor angular position so that the input armature current can be switched among the motor phases in exact synchronization with the rotor motion [9].

In this paper, BLDC hub motor is located on the rear wheel of the vehicle. BLDC hub motor can able to run the vehicle at a speed of 40km/hr. BLDC hub motors are compact and weight less motors and it has good inertia for free running. It is operated by applying 48 V DC source with the help of SLA (or) VRLA batteries [14]. Brake for this motor is placed in its outer casing and a brake for this BLDC hub motor is same as that of ordinary vehicles. Control of this BLDC hub motor is easier. Input for this motor is given from batteries whereas the motor takes the DC as input to the controller and the controller converts the DC to controlled AC and applies the AC supply to the windings of the BLDC motor. Power controllers with the hall sensor signals are used to vary the speed of the motor. Fig.5. shows the Experimental Setup BLDC hub motor of vehicle with energy storage.

In Table-II Represents the Specifications of the BLDC hub motor used in this paper are as follows:

**Table-II:** BLDC hub motor specifications

s.no	parameter	Rating
1	Power	600w to 1000w
2	Voltage	48v
3	Current	13-20A
4	Torque	0.92Nm
5	Speed	400RPM

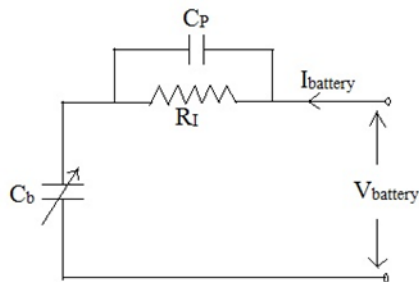


**Figure 5:** Experimental Setup BLDC hub motor

## ii. BATTERY SPECIFICATIONS

Charge Controller limits the rate at which electric vehicle current is added to or drawn from the electric batteries [8]. The prime purpose of using the Charge Controller is to prevent against overcharging and deep discharging of a battery. For the 12V/35 Ah battery, 12V/6A charge controller is an ideal choice. According to the rating of the battery and solar module, IC engine and Plug-in supply are the selection of the charge controller is done.

In this paper, four numbers of 12V 35 AH batteries connected in series to obtain 48V, 35 AH to run the BLDC hub motor. Fig.6. shows the Equivalent circuit of 35 AH/12 V battery.



**Figure 6:** Equivalent Circuit of Battery

$C_p$  – Polarization Capacitor in Farad  
 $C_b$  – Variable battery Capacitor in Farad  
 $R_i$  – Internal Resistor in Ohms  
 $V_{battery}$  – Battery Voltage in volts  
 $I_{battery}$  – Battery Current in Amps

The correct dimensions of battery establish the of Solar/Electric/Reduced Fuel consumption(IC Engine) Hybrid powered Vehicle (SEFPHV) technology. The goal is to search for a suitable relation among weight, volume, life time, cost, energy density and environmental impact. These factors must be expressed in the lowest possible weight and volume of the SEFPHV.

In Table-III Represents the Specifications of the Battery used in this paper are as follows:

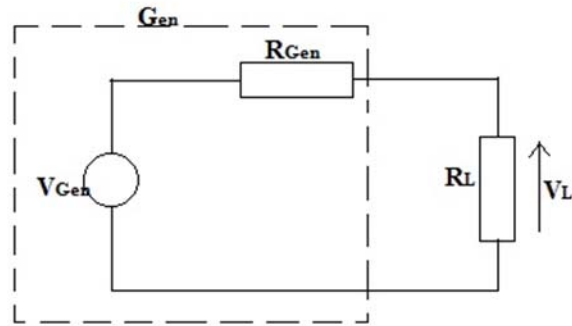
**Table-III:** Battery specifications

s.no	Parameter	Rating
1	Voltage	12 V
2	Capacity	35AH
3	Length	7 inches
4	Height	5inches
5	Width	4inches
6	Number of batteries used	4

### iii. PMDC GENERATOR SPECIFICATIONS

A Generator is a machine that converts mechanical energy into Electrical energy by using the principle of magnetic induction. Whenever a conductor is moved within a magnetic field in such a way that the conductor cuts across magnetic lines of flux, voltage are generated in the conductor. Direct current (DC) is the flow of an Electrical charge in one direction. PM motor magnet can either mounted on the rotor surface or buried inside the rotor circuit, the surface mounted machine construction is simpler and use for the low speed. These motors are considered small saliency thus having practically equal inductances in both axes [10].

In this Paper, the PMDC (Permanent Magnet Direct Current) generator operates with the basic principle of Fleming's left hand rule. When two stronger permanent magnets are placed around the rotating conductor the direct current will be generated. The polarity depends on the direction of the mechanical input given to it. Mechanical input for the generator is given by the IC-ENGINE. Power from the engine is transferred to a belt based transmission between the belt wheel and the PMDC generator's axle. Using this transmission, to generate a power of 200 watts continuously from the generator. Fig.7. shows the Equivalent Circuit for PMDC generator of vehicle The generator's  $V_{Gen}$  and  $R_{Gen}$  parameters can be determined by measuring the winding resistance (corrected to operating temperature), and measuring the open-circuit and loaded voltage for a defined current load & Fig.8. Shows the Experimental Setup for PMDC generator of vehicle with energy storage.



**Figure 7:** Equivalent Circuit of PMDC generator

Gen - Generator  
VGen- Generator open-circuit voltage  
RGen- Generator internal resistance  
VL- Generator on-load voltage  
RL- Load resistance



**Figure 8:** Experimental Setup PMDC generator

Using this PMDC generator, to generate the require power to charge the battery. Input for the dynamo is given by the IC-engine where as the output is given to the controller and the controlled output is given to battery. From this generator, 300 watts of power and 48 V DC as the output. It can be operated as a bidirectional operating generator and as per the requirement of clockwise directional rotation is performed to take the output.

In Table-IV Represents the Specifications of the PMDC used in this paper are as follows:

**Table-IV:** PMDC Motor specifications



S.No	Description	Ratings
1.	Voltage	55 V
2.	Current	4.636 A
3.	Speed	3000 Rpm
4.	Power	250 Watts
5.	Torque	0.62m

#### IV. CHARGE CONTROLLER & ALTERED IC ENGINE SPECIFICATIONS OF PROPOSED SYSTEM

##### i. SPECIFICATIONS OF CHARGE CONTROLLER

##### A. CONTROLLING THE OUTPUT OF PMDC GENERATOR

Power output from the PMDC generator is up to 55 V, 6A dc; it is connected to the controlled rectifier circuit which regulates the output current and voltage. Three NPN transistors are used to divide the voltage equally and regulate the current; to a maximum voltage of 110 V it allows only 48 V as the output from the circuit. The noise signal from the PMDC generator is reduced by using the capacitor and filter circuit of rating 100 $\mu$ f and a resistance of 200 $\Omega$  and with the use of Zener diode and a MOSFET controlled power is fed to batteries. The battery gets completely charged, input to the battery has to be kept opened. To keep the charging circuit open an IC 6308 is used to attenuate the input supply to the batteries and it indicates the charging using light emitting diodes [11].

The charge controller in this Paper, is for controlling the electrical power output from various sources, such as solar panel, Plug-in, and IC-engine. Controlled output from the charge controller is fed to charge the batteries. In this paper, solar power is one of the sources to charge the batteries. The DC output from the solar PV panel is supplied to the controller circuit which has a power of 80watts. The control circuit used for regulate the current and to stabilize the voltage from the solar panel. Fig.9. Shows the Experimental Setup of Charge Controller for PMDC generator and solar array.

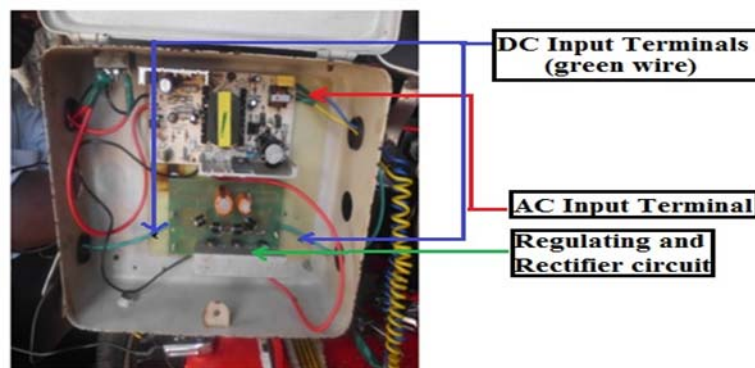
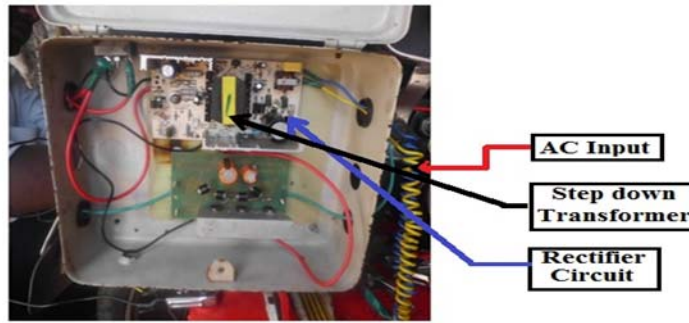


Figure 9: Experimental Setup of Charge Controller for PMDC generator and Solar array

##### B. CONTROLLING THE OUTPUT OF PLUG-IN Supply

To charge the batteries using grid power plug-in chargers are required and Plug-in supply are reduced to 230/48 V AC with the help of step down transformer and Converted into DC through Diode Rectifier. Before this conversion the fact that is to be considered is to step-down the single phase 230v AC supply to 48v AC using a step down transformer. The output from the step down transformer is connected to the rectifier circuit and it is again connected to the control circuit to charge the battery. Fig.10. Shows the Experimental Setup of Charge Controller for Plug-in supply.



**Figure 10:** Experimental Setup of Charge Controller for Plug-in supply

**Table-V:** IC Engine and Vehicle specifications

S.NO	Description	Rating
1.	IC Engine Type	2 Stroke air cooled
2.	CC	49.9 CC
3.	Maximum Power	2.61 KW
4.	Maximum Torque	5.0 @ 5000 RPM
5.	Wheel Base	1222 mm
6.	Tyre Size	2.5* 16
7.	Fuel Capacity	3 Lit
8.	Height	1750 mm
9.	Width	930 mm
10.	Ground Clearance	700 mm
11.	Drum brake	110 mm
12.	Cylindrical Bore	46 mm
13.	Total Weight(including Solar panel, PMDC, BLDC hub, Battery, Charge controller and Step-down Transformer)	166 kg

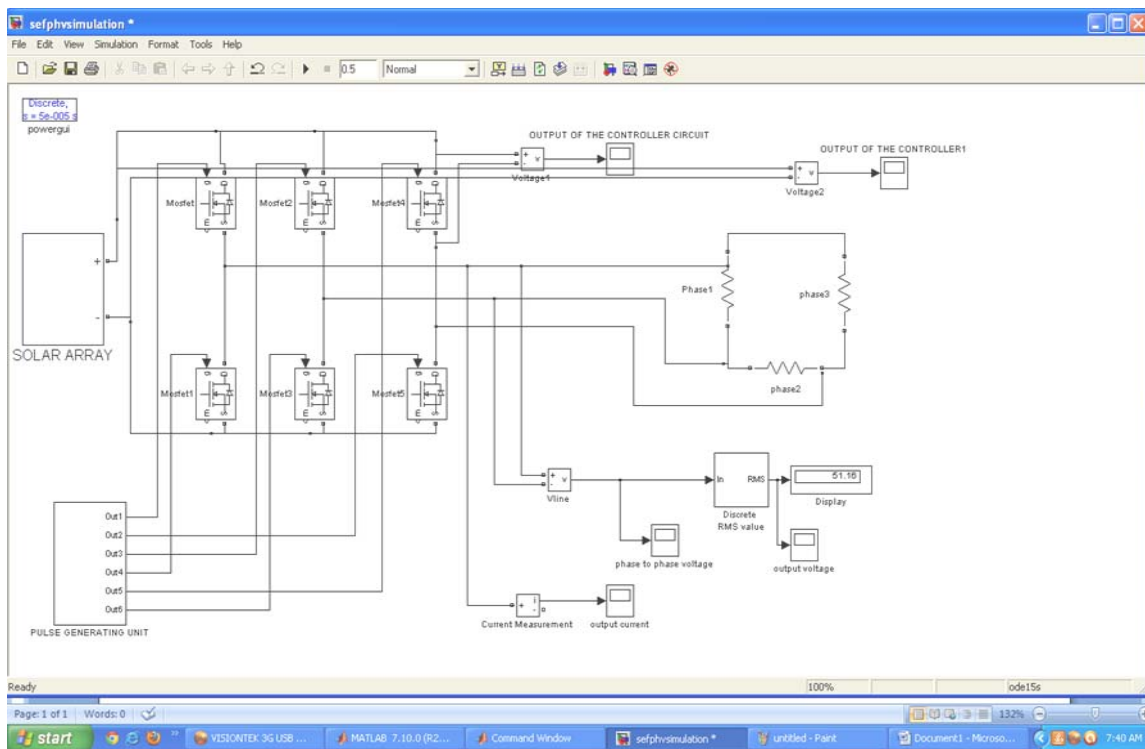
## V. SIMULATION RESULTS OF PROPOSED SYSTEM

In our proposed system, the simulated output of PV array modeling and Charge controller modeling using the MATLAB/ SIMULINK software is to be done. In Fig.11 shows the simulated circuit characteristic of the PV module, which controlled the MPPT using Rule base for the MATLAB/ SIMULINK software. At 5 Sec, this

converter starts estimating the maximum power point. After 7 Sec, the MPPT is completed. At this time, the simulated PV module reaches the maximum power of 230 W, and then, the output voltage and current of simulated PV module are 48 V and 5.2 A, respectively. In Fig.12 shows the Waveforms of the output voltage in volts. In Table-VI Represents the Specifications of the simulation parameters of the proposed system are as follows:

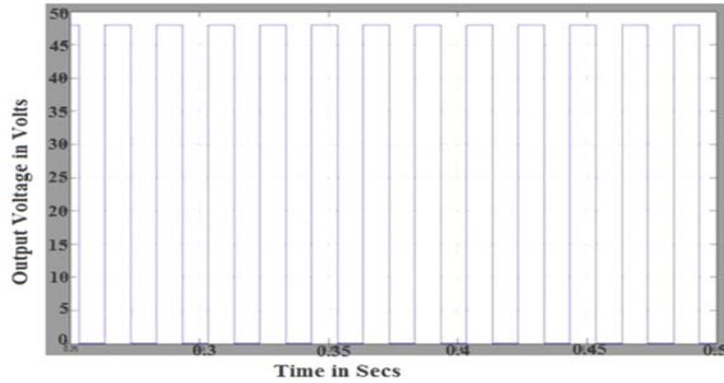
**Table-VI:** Simulation Parameters

S.NO	Parameters	Rating
1.	Temperature	25 deg
2.	irradiation	224.32 W/M <sup>2</sup>
3.	Short circuit current ( $I_{scn}$ )	5.16 A
4.	Open circuit voltage ( $V_{ocn}$ )	32.9 V
5.	input	Step
6.	Switch	MOSFET
7.	$L_{on}$	$1 \times 10^{-6}$ H
8.	$R_{on}$	0.001 ohm
9.	Output voltage	48 V
10.	Output current	8-14 A

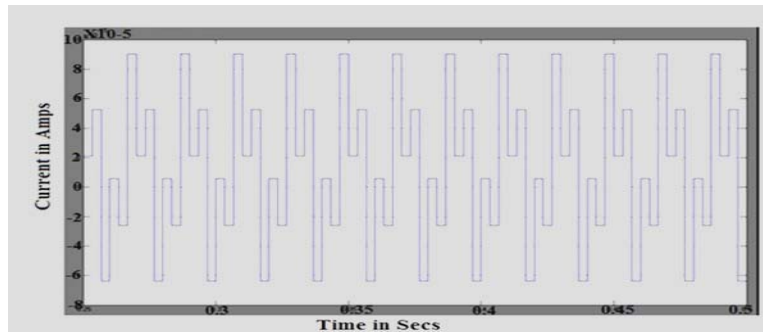


**Figure 11:** Simulation Setup of PV array for charge controller using Matlab/simulink software

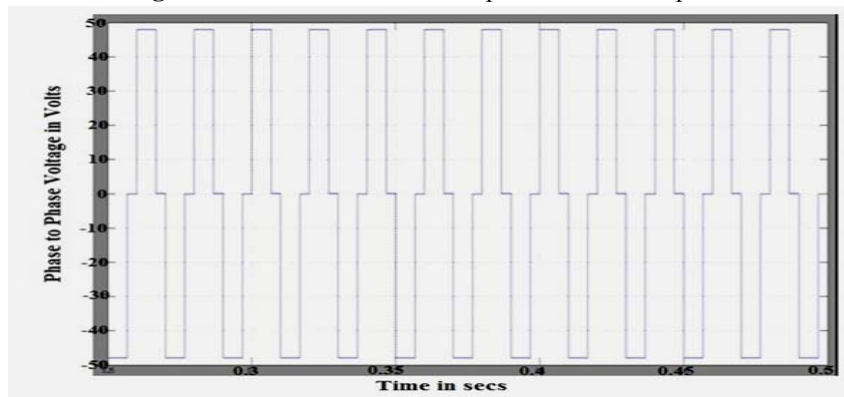
Fig. 13 shows the Waveforms of the output current in Amphere and Fig. 14 shows the waveforms of the Phase to Phase voltage in volts using Matlab/Simulink Software. Output of the charge controller can be connected to the vehicle to drive.



**Figure 12:** Waveforms of the output voltage in volts



**Figure 13:** Waveforms of the output current in Amphere



**Figure 14:** Waveforms of the Phase to Phase voltage in volts

## VI. HARDWARE SETUP OF SEFPHV

Hardware implementation of proposed Solar/Electric/Reduced Fuel consumption(IC Engine) Hybrid powered Vehicle (SEFPHV) technology are represented as shown in Fig.15 (A,B,C & D).

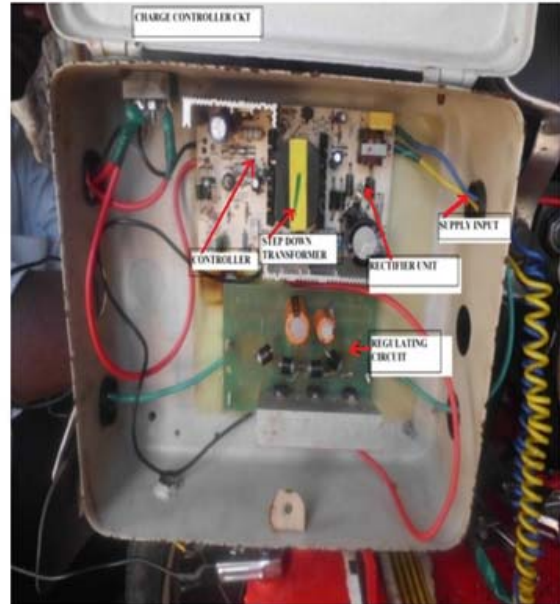
In this paper, Speed control switch are connected to the accelerator contact. The speed control of the PMDC motor is the essential part of the implementation of Solar/Electric/Reduced Fuel consumption(IC Engine) Hybrid powered Vehicle (SEFPHV) technology. For controlling speed of the motor, a switch was designed with 2 tapping, giving different values of resistance at each tapping, hence limiting the current that flows in the motor. The switch has been provided with two terminals; one for the motor connections and the other for the battery connections. The arrangement of the switch is more (or) less like a rheostat. The different tapping act as resistance points. With each increase in tapping valve, the valve of resistance decrease, thus at the last tapping the motor will run at the highest speed as the limiting resistance will be minimum whereas the high torque condition of the motor will arise when the minimum tapping will be used. Since the limiting resistance will be maximum. The mechanical energy produced by the IC Engine is to transferred to PMDC generator and convert Electrical energy. The produced Electrical energy is applied to charge controller and output of the charge controller is given for charging the battery. Two Solar panels each with a rating of 230 Watts are connected to the top of the vehicle to grab the solar energy and then controlled it with a help of charge controller. During sunless conditions, household Electric supply of 230V is reduced with a step-down transformer to 48V and then it is converted into DC with a rectifying unit to charge the batteries. Using the above additional methods are implemented and to reduce the fuel consumption in automobiles. The power from the additional sources is fed to the charge controller. Solar module mounted on the top of the vehicle is used to charge the batteries via charge controller.230watts solar module is used to charging the batteries and start the load on the motor is nearly 160 kg including the weight of two people driving and travelling it. The motor after starting acquires the maximum speed of 45kmph. The batteries get charged always from the solar panel and so it provides the power to run the vehicle. During the sunless conditions, electric supply are stepped down and converted to DC Power with help of diode rectifier and it is used to charging the battery. It provides the continuous run for the vehicle.

The specifications of entire SEFPHV system in this paper are represented in Table-VII

**Table-VII:** Integration setup of SEFPHV

Solar Panel-230 watts for single panel(2 panels)		BLDC hub motor (600 to 1000 watts)		PMDG generator (250 watts)		Charge controller		Diode rectifier		Step down transformer	
V (V)	I (A)	V (V)	I (A)	V (V)	I (A)	V (V)	I (A)	i/p (V)	o/p (V)	i/p (V)	o/p (V)
24	8.10	48	13-18	55	4.8	48	24	48V AC	48V DC	230V AC	48V AC

Fig.16. shows the waveforms of the comparison between the energy consumption in TVS-50 over SEFPHV. Fig.17 shows the waveforms of the Comparison between the Speed in Km/hr VS Battery voltage in volts. Fig.18 Shows the No .of batteries VS Distance in KM – SEFPHV. Fig.19 shows the waveforms of the efficiency calculations between the energy consumption in TVS-50 over SEFPHV. Fig.20 (A,B,C,&D) shows the waveforms of the comparison between the energy cost versus the distance for different energy sources. Fig.21 shows the waveforms for comparison of different energy sources



**Figure 15:** (A, B, C & D) Hardware Implementation – SEFPHV

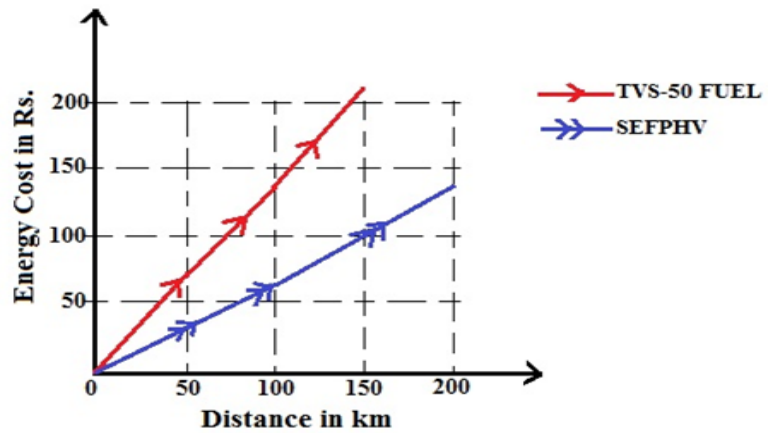


Figure 16: Energy cost in Rs VS Distance in KM

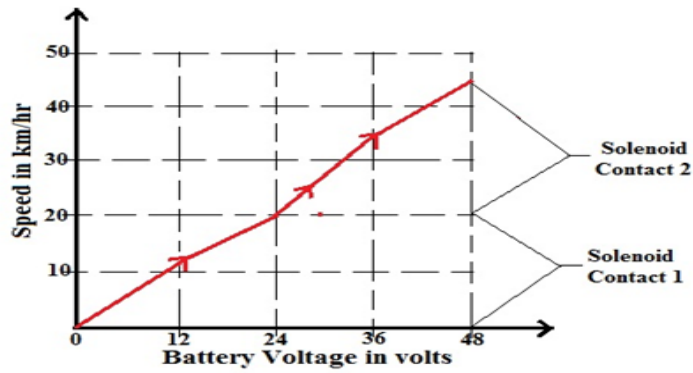


Figure17: Speed in Km/hr VS Battery voltage in volts – SEFPHV

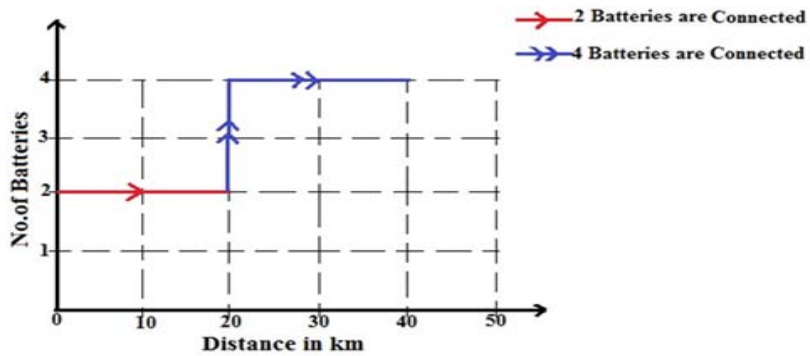


Figure18: No.of batteries VS Distance in KM – SEFPHV

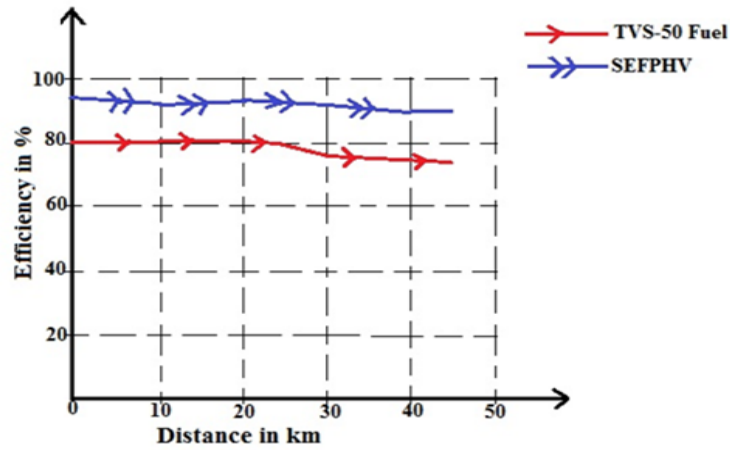


Figure 19: Efficiency in percentage VS Distance in KM

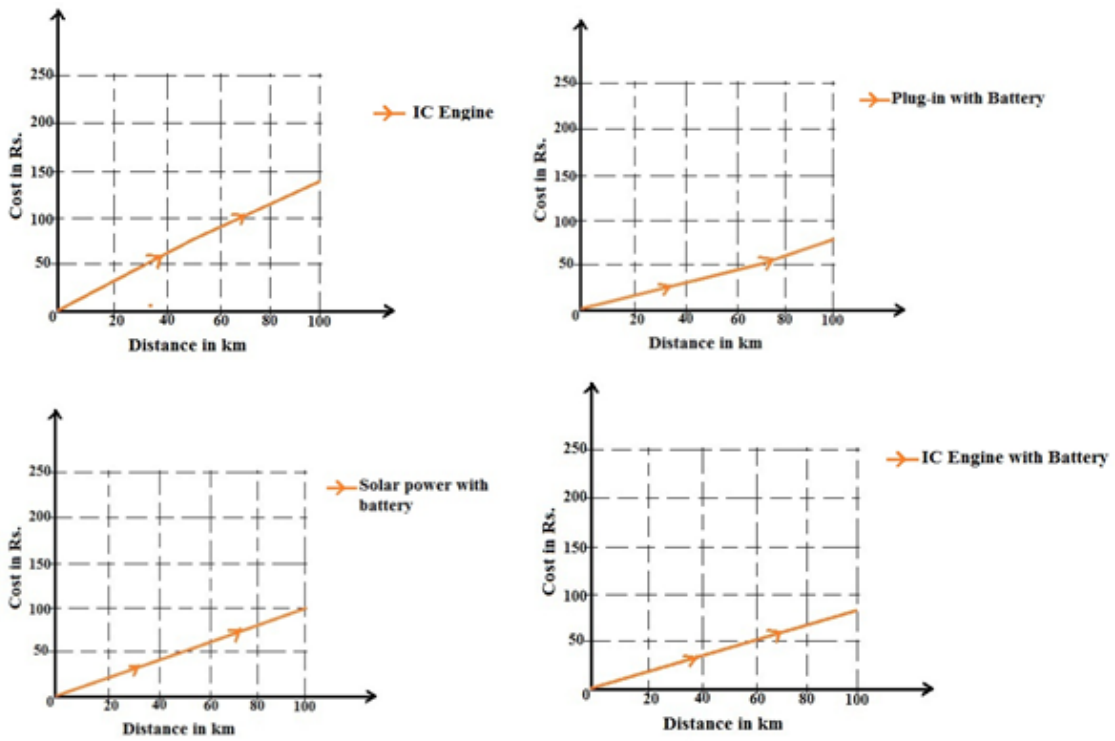
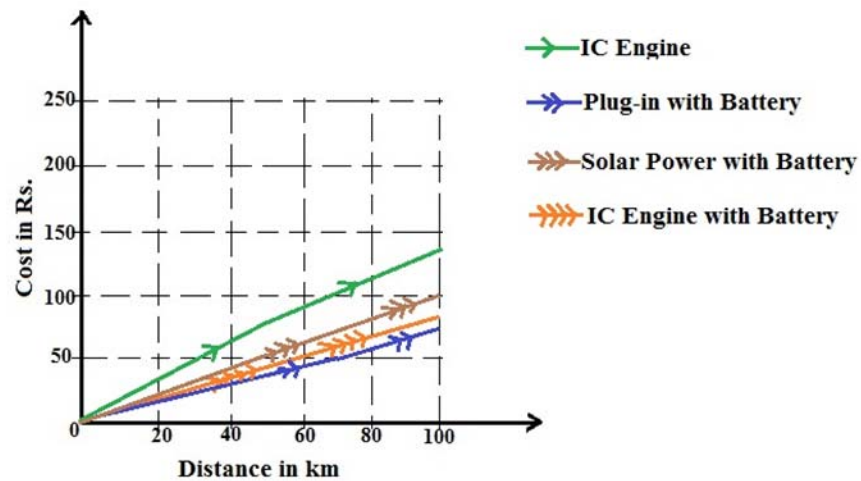


Figure 20: (A, B, C&D).Comparison of Energy Cost in Rs VS Distance in KM for Different sources





**Figure 21:** Waveforms for comparison of different energy sources

## VII. CONCLUSION

In this paper, a new implementation of Solar/Electric/reduced Fuel consumption (IC Engine) Hybrid Powered Vehicle (SEFPHV) technology is proposed and investigated and its solves many problems related to the environment and is the best pollution free method. This multi charging vehicle can charge itself from solar power, IC Engine (reduced fuel consumption) and electric power. Solar/Electric/reduced Fuel consumption (IC Engine) Hybrid Powered Vehicle (SEFPHV) technology is continuous running during all intervals. The vehicle is altered out of a TVS-50, by adding its engine with a 600 watts BLDC hub Motor, two 230 watts PV Panel, four 12 V/ 35 AH Battery and 250 watts PMDC generator. For controlling speed of the motor, a solenoid control switch is designed with two tapping, provided with different values of resistance at each tapping and it acts as a speed control switch for SEFPHV. The Solenoids are acting as the speed control switch. Initially, First accelerator contact is triggered, solenoid-I activates and two batteries are connected to the motor. When the second accelerator contact is triggered, solenoid-II activates and the four set of batteries are connected to the motor. This type of technique is to reduce the running cost and increasing the running efficiency of the vehicle. If the price is compared to petrol driven TVS 50 Vehicle, the cost per KM travelled will be Rs. 1.25. Here the distance covered by the SEFPHV in a 60 KM when the batteries are fully charged, then cost per KM travelled will be 0.45 paisa per KM. The efficiency and running time of the Solar/Electric/reduced Fuel consumption (IC Engine) Hybrid Powered Vehicle (SEFPHV) technology was improved and verified by simulation and experimental result.

## References

- [1] Marei,M.I;Samborsky,S.J;Lambert,S.B;Salama M.M.A, "On the Characterization of ultra capacitor Banks used for HEV" proceedings of the IEEE Vehicle power propulsion conference,VPPC'06,Windsor,UK,2006,PP1-6.
- [2] Char C.C and Chan. K.T (2001) Modern Electric Vehicle Technology, Oxford University press, oxford.
- [3] Buchi F.,Tsukada A.,Rodutz P., Garcia O., Ruge M.,etc(2002) "Fuel cell super capacitor hybrid Electric power train", The fuel cell world 2002,European Fuel cell forum conference, Lucerne,PP 218-231.

- [4] Khaligh A., and Z. Li, "Battery, Ultracapacitor, Fuel cell and hybrid energy storage systems for Electric, hybrid Electric, fuel cell and plug-in hybrid Electric vehicles" state of the art, IEEE transactions on vehicular Technology, Vol. 59, No. 6, 2806-2814, 2010.
- [5] Arise I, Rizzo G, Sorrentino M, "A Model for the optimal Design of a hybrid solar vehicle", Review of Automotive Engineering, Society of Automotive Engineers of Japan (JSAE), 2008, ISSN 1349-4724, 29-3, 439-447.
- [6] Preitl Z., Bauer P., Kulcsar B., Rizzo G, J. Bokor, Control Solutions for Hybrid Solar Vehicle Fuel Consumption Minimization In: Proceedings of the 2007 IEEE Intelligent Vehicles Symposium, Istanbul, Turkey, June 13-15, 2007.
- [7] Borchardt, N. Magdeburg, Kasper, R. Heinemann, W. "Design of a wheel-hub motor with air gap winding and simultaneous utilization of all magnetic poles", IEEE International Journal, 4-8 March 2012.
- [8] Olivier Tremblay, Louis-A. Dessaint, and Abdel-Allah Dekkiche, A Generic Battery Model for the Dynamic Simulation of Hybrid Electric Vehicles, 2007, pp. 284-289.
- [9] Dakshina M. Bellur and Marian K. Kazmierczuk, DC-DC Converters for Electric Vehicle Applications, 2007 IEEE, pp. 286-293.
- [10] Wen L. Soong et al "Field-Weakening Performance of Interior Permanent-Magnet Motors", IEEE Transactions on Industrial Applications, Vol. 38, No. 5, September /October 2002.
- [11] Oliver Tremblay, Louis A. Dessaint and Abdel-Allah Dekkiche, "A Generic Battery model for the Dynamic Simulation of Hybrid Electric Vehicles", 2007, pp. 284-289.
- [12] J. Connors, "On the subject of solar vehicles and the benefits of the technology," in Proc. ICCEP'07, 2007, 700-705.
- [13] Patterson, D. J.; Brice, C. W.; Dougal, R. A.; Kovuri, D. (1-4 June 2003). "The "Goodness" of Small Contemporary Permanent Magnet Electric Machines". vol. 2. IEEE. pp. 1195-1200
- [14] K. Agbossou, M. Kolhe, J. Hamelin, and T. K. Bose, "Performance of a stand-alone renewable energy system based on energy storage as hydrogen," IEEE Trans. Energy Convers., vol. 19, no. 3, pp. 633-640, Sep. 2004.
- [15] I. S. Kim, M. B. Kim, and M. J. Youn, "New maximum power point tracker using sliding-mode observer for estimation of solar array current in the grid-connected photovoltaic system," IEEE Transaction on Industrial Electronics, vol. 53, no. 4, 2006, pp. 1027-1035.
- [16] S. Shaheen, "California's zero-emission vehicle mandate," Institute of Transportation Studies, vol. UCD-ITS-RP-04-14, 2004.
- [17] M. W. Daniels and P. R. Kumar, "The optimal use of the solar powered automobile," Control Systems Magazine, IEEE, vol. 19, no. 3, pp. 12-22, 1999.
- [18] K. H. Nam, AC Motor Control and Electric Vehicle Applications, New York: CRC Press, 2010, pp. 295-307.
- [19] F. Li, J. Wang, and Z. Liu, "Motor torque based vehicle stability control for four-wheel-drive electric vehicle," IEEE VPPC'09, pp. 1596-1601, 7-10 Sept. 2009, Dearborn, MI.

[20] N. Mutoh, Y. Takahashi, and Y. Tomita, "Failsafe drive performance of FRID electric vehicles with the structure driven by the front and rear wheels independently," IEEE Trans. on Industrial Elec.vol.55, no. 6, 2008, pp. 2306-2315.

## Authors Biography



**Balamurugan T** was born in Chennai on NOV 16, 1985. He received the B.E. degree in Electrical and Electronics Engineering from the Anna University, Chennai in 2007, M.Tech degree in Power Electronics and Drives in PRIST University, Tanjore in 2011, MBA degree in Human Resource Management in Annamalai University, Chidambaram in 2009. Currently pursuing Ph.D degree in Renewable Energy Sources in Karpagam University, Coimbatore. He is currently working as Assistant Professor Department of Electrical and Electronics Engineering in MountZion College of Engineering and Technology, Pudukkottai, Tamilnadu and he is also a life time member of ISTE. He has a long experience in the design of control systems for power electronic converters and more exactly multi-phase and multilevel converters. He is currently working on advanced renewable energy based generators and energy management systems for future smart grids.



**Dr. S. Manoharan** took his B.E degree in Electrical and Electronics Engineering from Government College of Technology, Coimbatore in 1997, M.E degree in Electrical Machines from PSG College of Technology, Coimbatore in 2004 and Ph.D. in the area of Electrical Machines and drives from Anna University Chennai in July 2010. He has over 18 years of teaching experience. He is currently working as Professor and Head, Department of Electronics and Instrumentation Engineering in Karpagam College of Engineering, Coimbatore, Tamilnadu. He has published research papers in both National and international journals of repute and presented papers in National and International Conferences. He has published more than half a dozen-text books on Electrical and Electronics related fields. He is a life member of ISTE, SSI and member of IE (India) and IEEE. Presently under his guidance, there are 14 students are doing their doctoral work in Anna university Chennai and Karpagam university, Coimbatore